



The PCRS recommended approach to developing a Network Respiratory Symptoms Diagnostics Service Specification

1.0 The PCRS Respiratory Service Framework

Patients with respiratory symptoms and disease deserve a correct diagnosis and correct guideline driven care that is standardized, patient focused, delivered by a Health Care Professional (HCP) with suitable training and experience, at a site and within an appropriate timeframe to meet their needs. Sadly, patient groups such as the British Lung Foundation (BLF) and Asthma UK have recognised that too often this is not the case. The Respiratory Service Framework ([RSF](#)) developed by the Primary Care Respiratory Society (PCRS) attempts to demonstrate both the scope and detail of what can be delivered at a population level. The RSF builds on the work previously undertaken by PCRS to develop a series of care standards for GP practices as part of its Quality Award programme. With the rise of integrated care systems and general practice at scale, commissioners and service development managers tell us they are keen to improve care and reduce variability but needed a starting point.

The PCRS recommended approach to developing a network focused diagnostic service specification, is one element of this framework and has been written specifically to assist those looking to establish a patient-focused respiratory symptom diagnostic service locally.

The work has been designed to encourage and support the development of diagnostic hubs or other appropriate systems such as have been recommended in the NHSE Long Term plan. The population size would be that described in the Primary Care Network (PCN) or Integrated Care System (ICS) level.

The benefits of diagnostic services have been recognised by commissioners and indeed many areas have already started to plan their development and this suggested approach provides a template to aid that process, ensure standardisation and encourage high standards.

2.0 The Network Respiratory Diagnostics Service Specification

This paper describes an approach to developing a cost and resource modelled service specification for the diagnosis of chronic respiratory symptoms in adults aged 18 and over for a PCN sized population of 50,000 individuals. The common long-term conditions of asthma and chronic obstructive pulmonary disease (COPD) are the principle focus. However, any service must also support better diagnosis of uncommon respiratory disease and other non-respiratory conditions where patients present with symptoms that may be considered to be respiratory-related. The PCN is a population described within current NHS England (NHSE) structures, but the specification could be equally applied to populations in the other three countries of the UK. The PCRS approach is written with the expectation that a commissioner may need to extrapolate to greater population sizes.

2.1 Why has this specification been written?

We have a legacy of poor-quality diagnosis in both common and rare respiratory diseases. National audits ([NACAP](#)) and research using big data from general practice disease registers has shown for example that confidence in the diagnosis of COPD based on one key criteria – spirometry, is at worst 10% and at best 50%. A retrospective review of the General Practice Research Database and Optimum Patient Care Research Database between 1990 and 2009 found that opportunities for diagnosis were missed in 85% of patients in the 5 years prior to a diagnosis of COPD (Jones et al 2014). People with interstitial lung disease are usually diagnosed many years after they first present with symptoms. This represents an unacceptable situation that is inequitable to the resource and efforts that are

apportioned for earlier diagnosis of cancer yet the prognosis is often worse. Misdiagnosis exposes people to harmful pharmacotherapy that provides no benefit.

Breathlessness is a common and debilitating symptom and often regarded as self-inflicted (smoking) or age-associated by individuals who fail to seek medical help (Hopkinson and Baxter 2017). Breathlessness, particularly worsening breathlessness, is a strong prognostic indicator for hospitalisation and death (Figarska et al 2012). The drivers of chronic breathlessness are broad and often individuals will have multiple causation: tobacco, drug, alcohol dependence, obesity, deconditioning, respiratory disease (asthma, COPD, infection, bronchiectasis, Interstitial Lung Disease (ILD), lung cancer, TB, pulmonary embolism, asbestos lung disease, chest wall and diaphragm disease), non-respiratory disease (anaemia, liver disease, cardiac disease, thyroid disease, anxiety). Comprehensive and systematic assessment and diagnosis are critical steps to ensuring patients receive early and appropriate intervention and support whether they have one or multiple causes.

The purpose of a respiratory symptom diagnostic service should be to:

- Improve diagnosis of adults presenting in primary care with respiratory symptoms
- Increase the accurate and early diagnosis of adult asthma and COPD
- Improve the diagnosis of adults presenting in primary care with uncommon respiratory disease
- Enable identification (and appropriate referral) of patients with non-respiratory conditions who present in primary care with respiratory symptoms
- Ensure that patients are treated/referred to the appropriate care setting and in line with local guidance (including cough and breathlessness algorithms)
- Support the development and implementation of integrated diagnostic pathways for adults presenting with respiratory symptoms in primary care
- Ensure that users of the service have a coordinated and positive experience of care and that the service involves users in its development and responds to patient's views as part of regular review.

2.2 Closing the Observed/expected prevalence gap for COPD and asthma

- Acting on Respiratory symptoms
 - Breathlessness is thought to affect up to 10% of the adult population in the UK, increasing to 30% of older adults (Baxter 2017; Hopkinson and Baxter 2017)
 - Approximately two thirds of cases of breathlessness in adults are due to a pulmonary or cardiac disorder
- Asthma
 - Prevalence: 5.4 million people are estimated to be living with asthma in the UK – 1.1 million children and 4.3 million adults (Asthma UK)
- COPD
 - Prevalence: 1.2 million people living with a diagnosis of COPD in the UK with 115,000 people receiving a new diagnosis each year (BLF). Over two million people in the UK are estimated to be undiagnosed and so receive no treatment
 - One third of people with a new diagnosis of COPD learn this at an emergency presentation

The Taskforce for Lung Health ([TFLH](#)) plan and [Data Tracker](#) provides more information about the diagnosis of respiratory disease and how England is performing. A key metric is finding people who have COPD but are not diagnosed yet according to PHE modelling.

2.3 Diagnostic inaccuracy

- COPD: Estimates suggest that ~70% of people with COPD remain undiagnosed; diagnosis is often delayed until patients have progressed to moderate-severe disease; patients with COPD consult their GP repeatedly with respiratory symptoms prior to a diagnosis; a proportion of patients with a diagnosis of COPD are thought to have been wrongly diagnosed
 - Roberts et al 2016: Referral for suspected COPD led to a confirmed diagnosis in 61% of men and 43% of women
 - Shabab et al 2006: Among 8215 adults in England, 13.3% evidenced spirometry-defined COPD but >80% reported no respiratory diagnosis
- Asthma
 - Daines et al 2018: Under- and over-diagnosis of asthma in primary care
- New tests that are perceived as expensive (FeNO) or are difficult to achieve high quality consistently (spirometry)
 - BMA GPC position on GPs doing spirometry (not paid) – opportunity for a network approach but costing required in order to understand and confirm funding streams are adequate
- Inconsistent / limited / non-structured approaches to diagnosing respiratory symptoms are prevalent
- NHSE RightCare, Lung Taskforce, NHSE LTP and GP contract all highlight diagnosis as a key priority area
- Late diagnosis is common and costly

2.4 Calculating the burden of respiratory symptoms and diagnostic need

A network diagnostic service will need to plan according to any local burden of disease which will involve (1) Clearing the backlog of the currently respiratory symptomatic population (undiagnosed, misdiagnosed) and (2) Planning for a future annual expected incidence.

This table would need to be completed to describe the current burden. This could be done using data captured from GP patient records. A number of providers are available in the UK who are able with permissions to analyse records to do this. Such data is not currently collected nationally in an open source way.

1. Patients presenting with respiratory symptoms
2. Patients with undiagnosed asthma
3. Patients with undiagnosed COPD
4. Patients with potentially misdiagnosed asthma
5. Patients with potentially misdiagnosed COPD

1. Patients presenting with respiratory symptoms

A modelled estimate could be calculated for the number of adults aged 18 and over who:

- Have a risk factor for lung disease (smoking, at risk occupation) and have presented more than once a year for the last 2 years with a respiratory symptom and do not currently exist on an asthma or COPD register.
- Have received a respiratory antibiotic more than once per year for the last 2 years
- Have received a course of oral corticosteroid in the last 2 years but do not have another reason for this (e.g. autoimmune disease)

- d. Have received a respiratory inhaler in the last 2 years but do not have a diagnosis of COPD or asthma

PCNs and at greater scale geographies could work with GP data analysis providers in order to determine their own local burden.

2. Patients with undiagnosed asthma

PHE [Respiratory Atlas of Variation](#) (RAoV) provides modelling for the variation in percentage of patients with asthma on GP registers by CCG. Local data analysis working with local public health teams could help calculate the backlog of undiagnosed asthma. The incidence of asthma could be calculated as a modelled estimate using GP system data analysis of rates of new diagnosis of asthma per year (people who have a first event asthma diagnosis code added to their record).

3. Patients with undiagnosed COPD

The RAoV provides modelling for the expected / observed prevalence by CCG. Therefore, the backlog of undiagnosed COPD can be quantified.

4. Patients with potentially misdiagnosed asthma

A modelled estimate could be calculated based on the number of adults aged 18 and over who:

- a. Have an asthma code on their record but have not been issued an inhaler in the last 2 years
- b. Have an asthma code on their record but in the last 2 years have not had any codes entered for atopy, trigger, reversibility, variability or wheeze
- c. Have an asthma code on their record and have no evidence of having an objective assessment of airways inflammation or obstruction (PEFR diary, FeNO, spirometry)
- d. Have an asthma code on their record and have no evidence of having an objective assessment of airways inflammation or obstruction (PEFR diary, FeNO, spirometry) that has a positive finding in two out of three tests.

5. Patients with potentially misdiagnosed COPD

A modelled estimate could be calculated based on of the number of adults aged 18 and over who:

- a. Have a COPD code on their record but have not been issued an inhaler in the last 2 years
- b. Have a COPD code on their record but in the last 2 years have not presented with respiratory symptoms
- c. Have a COPD code on their record and have no evidence of having an objective assessment of airways obstruction (spirometry).
- d. Have a COPD code on their record and have no evidence of having an objective assessment of airways obstruction (Spirometry) that has a positive finding of a FEV₁/FVC or VC ration between 0.2 and 0.7

2.5 Responsible respiratory prescribing

The NHS medication bill for respiratory is high and overuse, misuse and underuse is well described. We recommend gathering data locally on:

1. Current overuse of ICS in diagnosed COPD.

This metric should reflect current and local guidelines about what constitutes overuse of ICS in patients with COPD. People with COPD may also have asthma. We recommend identifying appropriate or inappropriate ICS use in COPD by following the [“Going for Gold”](#) model.

Data is available at the [EPCT-2 Respiratory](#) dashboard – for example

Patients on triple therapy

Section 1: Introduction / Overview		
1.1	Title	Patients on triple therapy
1.2	Definition	Identifying the proportion of patients, receiving medication used to treat asthma/COPD, prescribed triple therapy based on receiving prescriptions for a combination of LAMA, LABA and ICS inhalers. Results presented for a 12 month rolling period.
1.3	Reporting Level	Practice level (aggregated to CCG).
1.4	Numerator	No. of patients receiving triple therapy (LAMA + LABA + ICS) within a 12 month period. Please refer to Appendix 2 (provided in a separate document) for the drug list for this numerator.
1.5	Denominator	No. of patients receiving any medication used to treat asthma/COPD within the reported 12 month rolling period. Please refer to Appendix 2 (provided in a separate document) for the drug list for this denominator.
1.6	Methodology	Numerator divided by denominator, reported as a percentage.
Section 2: Rationale		
2.1	Purpose	Triple therapy is the lowest value intervention according to the value pyramid developed by the London Respiratory Network. For both COPD and asthma, patients receiving triple therapy should be reviewed at least annually with a view to stepping down treatment.
2.2	Evidence and Policy Base	

2. Current overuse of high dose ICS in diagnosed asthma

Around 30% of patients with asthma are receiving high dose ICS. Opinion is that an estimated 10% of all asthma patients should be receiving high dose ICS.

3. Current use of inhalers in misdiagnosed COPD (using calculated figures described above)

If alternative diagnosis should have been asthma, then inhaler prescription was likely appropriate. Estimating costs may be challenging here as the outcome of a correct diagnosis is likely to incur costs for alternative treatment/s.

4. Current use of inhalers in misdiagnosed asthma (using calculated figures described above)

Determining misdiagnosed asthma may be challenging as the alternative diagnosis (breathing pattern disorder, vocal cord dysfunction) are very difficult to diagnose or treat.

5. Current use of inhalers in people with no diagnosis of asthma or COPD

Data may be available to support the definition of this metric through the CPRD database (Gayle et al 2019). However, costs involved are likely to be small/negligible as it is likely to only involve salbutamol @£1.50 per inhaler

Data for excess SABA prescribing using the EPCT-2 Respiratory dashboard could be derived as follows:

Excess SABA prescribing

Section 1: Introduction / Overview		
1.1	Title	Excess SABA prescribing
1.2	Definition	Identifying the proportion of patients prescribed preventer inhalers without antimuscarinics who were also prescribed 6 or more SABA inhalers. Figures are reported for a rolling 12 month period.
1.3	Reporting Level	Practice level (aggregated to CCG).
1.4	Numerator	No. patients prescribed 6 or more SABA inhalers in a 12 month period, who were also prescribed a preventer inhaler but not prescribed an antimuscarinic. Please refer to Appendix 2 (provided in a separate document) for the drug lists for this numerator.
1.5	Denominator	No. of patients prescribed a preventer inhaler (see numerator) but not an antimuscarinic (see numerator).
1.6	Methodology	Numerator divided by denominator, presented as a percentage.
Section 2: Rationale		
2.1	Purpose	The NRAD report highlighted that asthma patients who overused their SABA medication were at higher risk of death. This metric identifies patients who are potentially overusing SABA medication.
2.2	Evidence and Policy Base	

3.0 Who should the service be for?

The service is for people aged 18 and over who live or are registered with a GP within the Network area and where there is shared access to the referred patient's records:

1. Who continue to experience respiratory symptoms beyond an acute phase or diagnosis (such as URTI or pneumothorax) or where the symptoms are recurrent and when a long-term condition is being considered. The respiratory symptoms would be:
 - a. Recurrent wheeze and or chest tightness
 - b. Cough (beyond 8 weeks) (NICE CKS: <https://cks.nice.org.uk/cough#!scenario:2>)
 - c. Breathlessness that is recurrent or lasting longer than 6 weeks and reaching MRC 2 scale or more
 - 1 BLF online breathlessness test: <https://breathtest.blf.org.uk>
 - 2 NICE CKS: <https://cks.nice.org.uk/breathlessness#!scenario:1>
 - d. Recurrent 'chest infection'
2. With suspected asthma where the probability level is low or intermediate (BTS/SIGN 2017; Daines 2019; Stonham and Baxter 2019)
3. With a diagnosis of COPD or asthma where they have not responded as expected to treatment or the accuracy or quality of the diagnosis has come under question for this or other reasons
4. Who have been identified through data analysis (outlined above) to have:
 - a. Undiagnosed asthma or COPD
 - b. A respiratory diagnosis that does not fit diagnostic criteria (potential misdiagnosis)
 - c. Patients admitted to secondary care with a respiratory diagnosis but no previous diagnosis prior to admission.

3.1 What would this service provide?

1. Receipt and assessment of referral from any HCP within the Network or Hospital
2. Structured expert feedback using relevant guidance to the referrer prior to the first visit - if required - and after the final visit
3. Perform
 - a. Quality assured pre and post bronchodilator spirometry
 - b. FeNO testing
 - c. Exhaled CO testing
4. Analyse pre-referral tests, service tests and the clinical history to inform the patient and referring clinician of a probable diagnosis and expected next steps

3.2 What would the outputs of the service be?

1. **Standard service:** Sufficient information and advice from an expert to the patient and referrer that would allow the start of or continuation of a pathway for treating asthma or COPD within the primary care setting
2. **Higher level service:** Initiation +/- follow up of therapy for a new asthma or COPD diagnosis to be managed within the primary care setting
3. Escalation to a secondary or tertiary specialist for further advice, diagnostics or treatment from either level of service when a diagnosis has not been confirmed or there remains diagnostic doubt

3.3 What skillset is required within the service?

The service should be delivered by HCPs with appropriate training, experience and expertise in respiratory care (Lawlor et al 2017). Desirable skills, knowledge and training for HCPs delivering a respiratory diagnostic service may be:

- Completion of or working towards completion of respiratory assessment module/s, for example:
 - Diploma module in asthma
 - Diploma module in COPD

- NCSCT Training and Assessment Programme for Smoking Cessation or equivalent

Standard service:

- An expert HCP in asthma and COPD of sufficient banding and training to formulate and recommend a diagnosis and treatment
- An HCP with the training and qualification to **perform** the relevant tests
- An HCP with the training and qualification to **interpret** the relevant tests

Higher level service:

As above plus:

- A prescriber

3.4 What health professionals could work in or connect with the service?

- Physicians
 - GP (receive and refer patients; Standard/Advanced respiratory care)
 - A&E physician (receive and refer patients; Standard/Advanced respiratory care)
 - Consultant (accept referrals; Expert respiratory care)
- Nurses (Band 7 or 8) (work within the integrated care system)
 - Practice nurse (receive and refer patients; Advanced respiratory care)
 - Community nurse (receive and refer patients; Standard respiratory care)
 - Community pharmacists (community practice) (receive and refer patients; Standard respiratory care)
- Allied healthcare professionals (work within the integrated diagnostic system)
 - Band 4 healthcare assistants, lung physiology team, nursing assistants)
- Administrator/manager
- IT support

3.5 Working with patients and carers to co-design the service

PCRS recommends working with patients, carers and local or national patient representative groups to develop the service specification. Local knowledge about sites and travel and acceptability can only be determined by users. Seek help from [BLF](#) and [AUK](#) or your local patient groups.

4.0 Accommodating people with respiratory symptoms in the service

We have started to collect some data from experienced respiratory practitioners in diagnostic services about what is expected to be the number of people who can be seen per session and number of sessions required per week/month/year for the population needing testing

Number of people that can be seen in a ‘session’.

Relevant metrics that could be used for calculating an average ‘session’ length are in the NICE Resource Impact Appendices for diagnosis of asthma (<https://www.nice.org.uk/guidance/ng80/resources>) and may include:

- Average number of minutes of nurse time to perform objective tests (FeNO, spirometry, reversibility, peak flow, direct bronchial challenge, other?)
- Time allowed to review and repeat unusual tests
- Average number of minutes of [HCP] time to interpret data

Session length (hours)	4 hours
Average appointment duration for <i>new</i> patients	1 hour
Average appointment duration for <i>follow-up</i> appointment	0.3 hours

A typical new patient comprehensive consultation may consist of:

- FeNO: 10–15 minutes
- Spirometry: 20 minutes
- Reversibility: 45 minutes with a 20-minute rest period post bronchodilator
- PEFr: 10 minutes
- Review, interpretation and, if starting treatment, patient education: 30–40 minutes

Number of people who will DNA per session

Number of patients issued an appointment but not attending	20%
---	-----

Time taken to review referrals, write up results and conclusions and provide output back to referrer or into new service

HCP time per patient	0.25 hours
Administrative time (if available) per patient	0.25 hours

5.0 Workers within the service

We recommend the following metrics are calculated to understand the number of workers required per year allowing for leave, sickness selecting from the following skill sets:

- An expert HCP in asthma and COPD of sufficient banding and training to formulate and recommend a diagnosis and treatment
- An HCP with the training and qualification to **perform** the relevant tests (ARTP training, other qualification?)
- An HCP with the training and qualification to **interpret** the relevant tests
- A prescriber
- Management and administration

Number of HCPs (diagnosis and treatment)
Number of HCPs (performing tests)
Number of HCPs (interpreting test results)
Number of administration staff

6.0 Equipment and Consumables

These costs and volume are dependent on what is calculated from Sections 1.0 and 2.0 and 3.0. It is recommended that at least two of each machine (FeNO, exhaled CO and spirometry) be available to account to annual calibration and cleaning.

FeNO machine:

FeNO machines	2	Estimated cost
Consumables (bacterial filter, disposable mouth tubes)	Required per year	Estimated cost per year

- NICE Resource Impact Appendices for diagnosis of asthma (<https://www.nice.org.uk/guidance/ng80/resources>) indicates 5 machines for 100K population

Exhaled CO monitors:

Exhaled CO monitor	2	Estimated cost
Consumables (disposable mouth tubes, D pieces)	Required per year	Estimated cost per year

- 2016 estimates from the London Clinical Senate estimate 20 units for ~6000 tests conducted per year (<http://www.londonsenate.nhs.uk/wp-content/uploads/2015/04/The-expired-carbon-monoxide-CO-test-guidance-for-health-professionals.pdf>)

Spirometry:

Spirometry machines	2	Estimated cost
Consumables (filters, disposable mouth tubes)	Required per year	Estimated cost per year

Bronchial reversibility:

Drugs	Required per year	Estimated cost per year
Volumetric spacers	Required per year	Estimated cost per year

Peak flow:

Peak flow meter	Required per year	Estimated cost per year
Consumables (disposable mouth tubes)	Required per year	Estimated cost per year

7.0 Receipt and assessment of referral

The referral and assessment process are key to making the “hub” activity as efficient as possible. This is a pathway that needs to include more than the diagnostic specialists. Primary Care HCPs need to ensure basic history, examinations and tests are done that would ideally be available on referral to the service.

We recommend for breathlessness symptom the [Southwark Clinical Effectiveness](#) approach as an exemplar. It is based on work by [Impress](#) (BTS/PCRS collaboration) in 2012. A chronic cough approach would also be required and could be agreed locally. Here is an example of a [Chronic Cough Algorithm](#) though others exist.

8.0 Testing protocol within the Service

This section will detail protocols for objective testing to be conducted following patient referral to the service. Test should be conducted in the following order: FeNO, exhaled CO, spirometry and reversibility.

Protocol for FeNO testing

Devices for this test are available from a number of companies. This protocol is an example provided by PCRS committee member Joanne King (King Edward VII Hospital, Berkshire); see Appendices for full protocol. Please use the [PCRS community platform](#) to connect with other members who may be using different devices.

Measuring Fractional Exhaled Nitric Oxide (FeNO) using a Bedfont NObreath meter

1. Obtain informed consent from patient prior to starting test. The patient should be seated. Turn the unit on WITHOUT the flow meter attached. The unit should be in an upright position with the rear exterior port NOT occluded.
2. Attach a new mouthpiece to the flowmeter.
3. Once secured, attach the flowmeter with mouthpiece to the device.
4. Instruct the patient to sit upright, put on a nose clip and hold the machine upright, with the display screen and mouthpiece towards them. Do not cover the rear exterior port.

5. Select either the adult icon or child icon (<12 years of age) depending on your patients age. The child icon requires young participants to blow for 10 seconds, adults for 12 seconds.
6. The machine will beep once. Ask the patient to inhale deeply away from the mouthpiece
7. After three seconds the machine will beep twice - ask the patient to place the mouthpiece in their mouth and exhale moderately, ensuring the silver ball is raised up into the white tabbed region of the flowmeter.
8. Patients should continue to exhale until the progress bar has reached its limit (after 10 or 12 seconds)
9. The machine will beep again, and you will see a measurement on the screen in parts per billion (ppb)
10. Repeat once more, giving two results. These results should be reproducible, i.e. within 10%. The test must be repeated until two sequential results are within 10% of each other, up to a maximum of 8 attempts.

Protocol for Exhaled CO

Follow these links to understand how to use exhaled CO monitoring in practice.

- NHSE London Senate "[Helping Smokers Quit](#)" [Exhaled CO Guidance](#)
- Primary Care Respiratory Update on [Exhaled CO test](#) from PCRS
- NCSCT Standard Treatment programme including [CO testing](#)

Protocol for spirometry

Devices for this test are available from a number of companies. This protocol is an example provided by PCRS committee member Joanne King (King Edward VII Hospital, Berkshire); see Appendices for full protocol

1. Review for contraindications for spirometry	<ul style="list-style-type: none"> • Haemoptysis (blood in sputum) • Pneumothorax (puncture in the lung wall) • Unstable heart disease e.g., angina • Unstable hypertension (high blood pressure) • Aneurysm (ballooning) chest, abdomen, cerebral • Recent eye surgery (advice from surgeon) • Acute illness/disorders • Recent thoracic/abdominal surgery (advice from surgeon)
2. Prepare spirometer	<ul style="list-style-type: none"> • Prepare equipment as per manufacturer's instructions • Accuracy check to be performed prior to clinic and then every 4 hours. A 3L or 1L Syringe is to be used, calibration should produce a measured value within +/- 3% • Spirometer should be kept at room temperature if possible • Cleaning and maintenance - as per manufacturer's instructions, for destruction of pathogens by chemical means
3. Infection prevention	<ul style="list-style-type: none"> • One Way filters - disposable (single patient use) • Calibration - all components assembled - check for leaks (keep at same temperature as room) If calibration pre-set, use

	<p>physiological check (member of staff with known normal values) Record data</p> <ul style="list-style-type: none"> • If patient known or suspected MRSA, TB, HIV, Pseudomonas infection, or Hep B, use a SafeTway mouthpiece or a BVF (single patient use) and preferably perform spirometry at the end of clinic
<p>4. Perform procedure</p>	<p>Explain and demonstrate each procedure to the patient, ensure patient is sitting comfortably:</p> <ol style="list-style-type: none"> 1. Relaxed VC (Vital Capacity) x 3 blows <ul style="list-style-type: none"> • Nose clip should be worn during this manoeuvre • Take a deep breath in. Put mouthpiece into mouth behind front teeth, and then exhale as far and as long as possible in their own time. • Verbally encourage ++ • Need two blows within 5% or 100mls of each other • Remove nose clip 2. Forced VC x 3 blows (nose clip is not essential) <ul style="list-style-type: none"> • As above for inspiration • Blow out as hard and as fast as possible for as long as possible - maximum effort needed • Verbally encourage ++ • Observe the flow/volume curve as each FVC manoeuvre is being performed to identify slow starts, early stops or variability in flow within manoeuvre • Need best of two blows within 5% or 100mls to 150mls of each other • Maximum of 8 blows at one sitting <p>If patient is unable to achieve these standards, document why this is and consider rebooking or referring to clinic medical team.</p> <p>BRONCHODILATOR REVERSIBILITY (using a SHORT ACTING BRONCHODILATOR)</p> <ul style="list-style-type: none"> • Baseline FEV₁, FVC, VC recorded as above • Ensure technically acceptable baselines before the administration of a Short Acting Beta Agonist (SABA) - 2.5mg Salbutamol administered via a nebuliser or 400mcg Salbutamol inhaler (4 Puffs) via disposable Spacer device • The SABA administration should be discontinued if the patient complains of symptoms such as increased shortness of breath/wheeze, palpitations, flushing • The monitoring of the patients pulse rate and BP is recommended for susceptible patients ie Hyperthyroidism, cardiovascular disease, arrhythmias, hypertension • After the short acting bronchodilator has been administered wait for 20minutes then repeat spirometry recording - FEV₁, FVC, VC

	<ul style="list-style-type: none"> • In Asthma - an increase in FEV₁ of 200mls/12% may indicate Asthma • In COPD – A limited degree of reversibility or none would indicate COPD. Post bronchodilator FEV₁ % is recorded for classification of disease (GOLD classification) <p>Consider oral steroid trial (30mgs oral prednisolone for 2 / 52) and repeat forced blows</p> <p>Transfer results onto spirometry template in the notes and flow/volume and time/volume graphs to be secured or scanned into the patients notes.</p>
--	--

9.0 Best practice examples of referrer and patient feedback and information

The [PCRS community platform](#) has active members who have developed local referrer protocols and letters back to referrers and for patients. See **Appendix 3** for an example referral letter designed to merge data from GP systems.

10.0 Recommended coding

Evaluation of the service will require the use of consistent coding and can be supported by consultation templates. This will also help with searching for people with potential inaccurate diagnosis and suspected diagnosis. We recommend using the [codes](#) selected by the National asthma and COPD audit with examples below.

Read Code	v2 Term30	SNOMED conceptid	SNOMED descriptionid
H3...00	Chronic obstructive pulm.dis.	13645005	475431013
H33	Asthma	195967001	301485011
H3122	Acute exacerbation of chronic obstructive airways disease	195951007	301453013
H333	Acute exacerbation of asthma	304527002	446841017
137R	Current smoker	77176002	503483019
137S	Ex smoker	8517006	15047015
66Yf	Numb COPD exacer in past year	723245007	3335171010
663y.	Num asthm exacs in past year	366874008	490425015
8H7i.	Referral: smok cessatn advisor	395700008	1489355012
745H4	Smoking cessation drug therapy	713700008	3297364011

11.0 Performance and Quality Metrics

We recommend review of the measurables that have been developed over the last decade by the [RCP NACAP](#) team as they represent a continuous consensus of standards across disciplines and stakeholders. They can assist you to decide and agree a Quality Improvement strategy in Pulmonary Rehabilitation, in primary care and in hospitals. Whilst the primary care queries are only being asked in Welsh practices there could still be opportunities to collect data on progress locally

The TFLH [data tracker](#) describes the key metrics decided by this group of 29 professional , patient and other stakeholders.

12.0 Integrating the network service to secondary and tertiary care

We recommend the [Respiratory Futures](#) site to see what is happening with integration of primary secondary and tertiary services locally and regionally. We have more respiratory physicians, nurses, physiotherapists, pharmacists and physiologists than ever who are working together across traditional boundaries to ensure pathways make sense for patients and for workforce efficiencies and resilience.

This paper was developed through conversation between providers, commissioners, patients who have experience of or work in all tiers of the health service. When you develop your plan we recommend that make sure these people are also at your table

We're grateful to our corporate supporters AstraZeneca UK Ltd, Boehringer Ingelheim Ltd, Chiesi Ltd, Cipla EU Ltd, Circassia Pharmaceuticals plc and Napp Pharmaceuticals for their financial support which supports the core activities of the Charity and allows PCRS to make its services either freely available or at greatly reduced rates to its members. [See PCRS statement on pharmaceutical funding.](#)

Charity Number 1098117 Company Number 4298947 VAT Registration Number 866 1543 09
Registered office Miria House, 1683b High Street, Knowle, B93 0LL Telephone +44 (0)1675 477600
Email info@pcrs-uk.org Website <https://www.pcrs-uk.org>

References

- Baxter N. Breathlessness in the primary care setting. *Curr Opin Support Pall Care* 2017;11:152-158.
- BTS/SIGN. SIGN 153. British guideline on the management of asthma. Published September 2016. Available at: <https://www.brit-thoracic.org.uk/document-library/clinical-information/asthma/btssign-asthma-guideline-2016/>. Accessed May 2019.
- Daines L, et al. Clinical prediction models to support the diagnosis of asthma in primary care: a systematic review protocol. *npj Prim Care Respir Med* 2018;28:15.
- Daines L. Asthma guidelines in practice – A PCRS-UK consensus. PCRU 2019
- Figarska SM, Boezen HM, Vonk JM. Dyspnoea severity, changes in dyspnoea status and mortality in the general population: The Vlagtwedde/Vlaardingen study. *Eur J Epidemiol.* 2012;27:867–876
- Gayle A, et al. Real-life prescribing of asthmatic treatments in UK general practice over time using 2014 BTS/SIGN steps. *npj Prim Care Respir Med* 2019;29:25
- Gray M. Value based healthcare. *BMJ* 2017;356:j437.
- Hopkinson S, et al. Breathing SPACE – a practical approach to the breathless patient. *Npj Primary Care Respir Med* 2017;27:5.
- Jayatunga W, et al. Code sets for respiratory symptoms in electronic health records research: a systematic review protocol. *BMJ Open* 2019;9:e025965.
- Jones RCM, et al. Opportunities to diagnose chronic obstructive pulmonary disease in routine care in the UK: a retrospective study of a clinical cohort. *Lancet Respir Med* 2014;2:267–276.
- Lawlor R. Fit to care: key knowledge skills and training for clinicians providing respiratory care. PCRS-UK/FTC/JUN2017/V1. Available at: https://www.pcrs-uk.org/sites/pcrs-uk.org/files/FitToCare_FINAL.pdf. Accessed May 2019.
- Pearson M, et al. Diagnosis of airway obstruction in primary care in the UK: the CADRE (COPD and Asthma Diagnostic/management Reassessment) programme 1997-2001. *Int J Chron Obstruct Pulmon Dis* 2006;1:435-43.
- Roberts NJ, et al. The diagnosis of COPD in primary care; gender differences and the role of spirometry. *Respir Med* 2016;111:60-63.
- Shabab L, et al. Prevalence, diagnosis and relation to tobacco dependence of chronic obstructive pulmonary disease in a nationally representative population sample. *Thorax* 2006;61:1043-1047. [Jennifer Quint is currently running a study to identify code sets for the identification of patients with respiratory symptoms in electronic health records]
- Stonham C, Baxter N. FeNO testing for asthma diagnosis – A PCRS consensus. *In preparation*.
- Ward DG, et al. How accurate is diagnosis of asthma in a general practice dataset? A review of patients' notes and questionnaire-reported symptoms. *Br J Gen Pract* 2004;54:753-758.

TRUST SPIROMETRY PROTOCOL

Measuring Fractional Exhaled Nitric Oxide (FeNO) using a Bedfont NObreath meter

- Nitric oxide (NO), produced in the lungs and present in exhaled breath, has been shown to act as an inflammatory mediator in the lungs and airways
- Eosinophilic asthma is a distinct phenotype associated with a rise in NO in exhaled breath
- Eosinophilic asthma may respond to treatment with corticosteroids, while neutrophilic asthma generally does not
- FeNO can be used to measure steroid responsive, eosinophil driven airway inflammation
- Higher levels of airways inflammation are associated with poor asthma control
-NICE, 2014

Measured in parts per billion (ppb):

- Low range: <25ppb in adults, <20 in children *
- Intermediate range: 25-50ppb in adults, 20-35 ppb
- High range: >50 in adults, >35 in children **
-

* In atopic individuals, higher values may be considered normal

** In patients with a value >50ppb(adult) / 35ppb (child), who are on high dose ICS, adherence may be questioned (McNicholl et al 2012)

FeNO may be suppressed by smoking, oral or inhaled corticosteroid, exercise, alcohol consumption, bronchoconstriction, ciliary dyskinesia, pulmonary hypertension, cystic fibrosis

FeNO may be higher in airway infection, allergic rhinitis, nitrate-rich diet, bronchodilator (Taylor et al 2006)

Procedure

FeNO testing should be undertaken BEFORE spirometry

11. Obtain informed consent from patient prior to starting test. The patient should be sat down. Turn the unit on WITHOUT the flow meter attached. The unit should be in an upright position with the rear exterior port NOT occluded.
12. Attach a new mouthpiece to the flowmeter.
13. Once secured, attach the flowmeter with mouthpiece to the device.
14. Instruct the participant to sit up, put on a nose clip and hold the machine upright, with the display screen and mouthpiece towards them. Do not cover the rear exterior port.
15. Select either the adult icon or child icon (less than 12 years of age) depending on your participant's age. The child icon requires young participants to blow for 10 seconds, adults for 12 seconds.

16. The machine will beep once, ask participant to inhale deeply away from the mouthpiece
17. After three seconds the machine will beep twice - ask the participant to place the mouthpiece in their mouth and exhale moderately, ensuring the silver ball is raised up into the white tabbed region of the flowmeter.
18. Participants should continue to exhale until the progress bar has reached its limit (after 10 or 12 seconds).
19. The machine will beep again and you will see a measurement on the screen in parts per billion (ppb).
20. Repeat once more, giving two results. These results should be reproducible, i.e. within 10%. The test must be repeated until two sequential results are within 10% of each other, up to a maximum of 8 attempts.

References:

- “ NICE (2014) *Measuring FeNO concentration in asthma*.
<http://www.nice.org.uk/guidance/dg12/resources/measuring-fractional-exhaled-nitric-oxide-concentration-in-asthma-niox-mino-niox-vero-and-nobreat-1053626430661>
- “ McNicholl, D.M., Stevenson, M., McGarvey, L.P., Heaney, L.G. (2012) ‘The utility of fractional exhaled nitric oxide suppression in the identification of nonadherence in difficult asthma’. *American Journal of Respiratory Critical Care Medicine*. 186(11), pp1102-1108.
- “ Taylor DR, Pijnenburg MW, Smith AD, De Jongste JC. Exhaled nitric oxide measurements: clinical application and interpretation. *Thorax*. 2006;61(9):817-27.

Appendix 2: Spirometry protocol

Provided by Joanne King (King Edward VII Hospital, Berkshire)

TRUST SPIROMETRY PROTOCOL

PRE-TEST REQUIREMENTS

Health and Safety of patient

Documentation of medications used prior to test.

Ensure patient is sitting down during tests.

Explanation leaflet for patient with instructions, ideally when booking for test

Patients condition must be stable

Ideally patient should avoid:

- Smoking for 24 hours (or shorter if unable to comply)
- Alcohol for 4 hours
- Exercise for 30 minutes
- Eating substantial meal for 2 hours

For diagnostic spirometry, patient should avoid:

- Taking short acting bronchodilators for 4 hours (Salbutamol Terbutaline)
- Taking long acting bronchodilators for 24 hour(Tiotropium, Salmeterol, Formoterol)

For follow up spirometry, all inhaled therapy should be taken as usual, prior to test.

Bring all inhalers to appointment

All patients should wear comfortable, non restrictive clothing

Wear dentures if possible. Females empty bladder

Patient should arrive early for appointment, as need to be seated 10 minutes to settle any exertional dyspnoea

Check information before test and record any deviation

Accurate height and weight should be recorded.

CONTRAINDICATIONS FOR SPIROMETRY

- Haemoptysis (blood in sputum)
- Pneumothorax (puncture in the lung wall)
- Unstable heart disease e.g., angina
- Unstable hypertension (high blood pressure)
- Aneurysm (ballooning) chest, abdomen, cerebral
- Recent eye surgery (advice from surgeon)
- Acute illness/disorders
- Recent thoracic/abdominal surgery (advice from surgeon)

PREPARATION OF SPIROMETER

- Prepare equipment as per manufacturer's instructions

- Accuracy check to be performed prior to clinic and then every 4 hours. A 3L or 1L Syringe is to be used, calibration should produce a measured value within +/- 3%
- Spirometer should be kept at room temperature if possible
- Cleaning and maintenance - as per manufacturer's instructions, for destruction of pathogens by chemical means.

FREQUENCY OF CLEANING - best practice would include daily, post session and weekly documented cleaning procedures.

Must be disinfected every 100 patients or monthly. (Please see Cleaning Protocol)

FREQUENT HAND WASHING TO PREVENT INFECTION BETWEEN INDIVIDUALS

One Way filters - disposable (single patient use)

Calibration - all components assembled - check for leaks (keep at same temperature as room) If calibration pre-set, use physiological check (member of staff with known normal values) Record data

If patient known or suspected:

- MRSA
- TB
- HIV
- Pseudomonas
- Hep B

Use a SafeTway mouthpiece or a BVF (single patient use) and preferably perform spirometry at the end of clinic.

Procedure

Equipment and patient prepared as above, explain and demonstrate each procedure to the patient, ensure patient is sitting comfortably:

3. Relaxed VC (Vital Capacity) x 3 blows
 - Nose clip should be worn during this manoeuvre.
 - Take a deep breath in. Put mouthpiece into mouth behind front teeth, and then exhale as far and as long as possible in their own time.
 - Verbally encourage++
 - Need two blows within 5% or 100mls of each other
 - Remove nose clip
4. Forced VC x 3 blows (nose clip is not essential)
 - As above for inspiration
 - Blow out as hard and as fast as possible for as long as possible - maximum effort needed
 - Verbally encourage ++
 - Observe the flow/volume curve as each FVC manoeuvre is being performed to identify Slow starts, Early stops, Variability in flow within manoeuvre
 - Need best of two blows within 5% or 100mls to 150mls of each other

- Maximum of 8 blows at one sitting

If patient is unable to achieve these standards, document why this is and consider rebooking or referring to clinic medical team.

BRONCHODILATOR REVERSIBILITY (SHORT ACTING BRONCHODILATOR)

- Baseline FEV₁, FVC, VC recorded as above
- Ensure technically acceptable baselines before -

BRONCHODILATOR REVERSIBILITY (using a SHORT ACTING BRONCHODILATOR)

- Baseline FEV₁, FVC, VC recorded as above
- Ensure technically acceptable baselines before the administration of a Short Acting Beta Agonist (SABA) - 2.5mg Salbutamol administered via a nebuliser or 400mcg Salbutamol inhaler (4 Puffs) via disposable Spacer device
- The SABA administration should be discontinued if the patient complains of symptoms such as increased shortness of breath/wheeze, palpitations, flushing
- The monitoring of the patients pulse rate and BP is recommended for susceptible patients ie Hyperthyroidism, cardio vascular disease, arrhythmias, hypertension
- After the short acting bronchodilator has been administered wait for 20minutes then repeat spirometry recording - FEV₁, FVC, VC
- In Asthma - an increase in FEV₁ of 200mls/12% may indicate Asthma
- In COPD – A limited degree of reversibility or none would indicate COPD. Post bronchodilator FEV₁ % is recorded for classification of disease(Gold classification)

Consider Oral Steroid trial (30mgs oral Prednisolone for 2 / 52) & repeat forced blows

Transfer results onto spirometry template in the notes and flow/volume and time/volume graphs to be secured or scanned into the patients notes.

ACCOUNTABILITY

Factors that impact on a Health Care Professional / Health Care Assistant when conducting a spirometry assessment;

1. Code of professional conduct.
2. Accountability for actions and omissions.
3. Duty of care to your patients and clients who are entitled to receive safe and competent care.
4. Duty to maintain and increase your knowledge, skills and abilities required for lawful, safe and effective practice
 - a) within direct/ indirect supervision - HCA

- b) without supervision - qualified clinician
- 5. Acknowledge limitations of professional competence and only accept responsibilities at which you are competent.
- 6. Adherence to the spirometry protocol

Reference: PPC (2013) Guide to performing Quality assured Spirometry

Trust Protocol for calibration/verification of Spirometers

All spirometry standards (e.g. ATS/ERS/BTS/ANZRS) recommend checking

the accuracy of lung function measuring devices at least daily with a 3-L

syringe to validate that the instrument is measuring accurately. The

Vitalograph ALPHA should never be outside accuracy limits unless damaged

or in a fault condition. In normal use, calibration traceability certification is

recommended as a part of the routine annual service. ATS (1994)

recommendations require that the difference between the volume measured

by the spirometer and the volume pumped into the spirometer from a syringe

is within 3%.

The purpose of calibrations or verification of the spirometer is to ensure that the device produces accurate results; inaccurate results could lead to inappropriate treatment for patients.

The health care professional performing the accuracy check has been trained and completed local trust competency on preparing the device and performing spirometry.

Pre check

Check for visible damage to device and cables – withdraw from service and report to the medical device department for repair, follow trust guidelines in reporting faults.

Check for any contamination to the flow head. If there is visible contamination then withdraw the device from service and follow the cleaning protocol.

Check that all components are assembled correctly.

Check for any leaks by using the calibration syringe.

Check room temperature, document in verification log.

Accuracy Check

A 1litre syringe is provided to use, the calibration should produce a measured value of 3Litres within a 3% margin.

An accuracy check should be performed:

Before each clinic session or every 4 hours if used all day.

After every 10 patients

If there is a change in ambient temperature

If the flow head is dropped

After cleaning or dismantling of the spirometer for any reason

Follow these steps to check the accuracy of the unit.

1. Pump air through the flow head to ensure it's at ambient temperature, may require several pumps if spirometer has been moved from a cold environment.
2. Select Accuracy Check from the Main Menu using the keypad.
3. Press the 'Enter' key to bring you into the Accuracy Check screen and follow the on-screen instructions.

Note: Press the 'Del' key to exit the Accuracy Check screen and return to the Main Menu. The accuracy check will not be logged to the Vitalograph ALPHA memory in this case.

4. If an Accuracy Check report is required select the Report option.

Note: If the device is outside calibration you will be given the option to update the calibration. If you select this option you will be brought through the accuracy check routine again.

5. Complete calibration log book and sign.

In the event the accuracy check is outside the +/-3%, then refer to the manufacturer's manual on fault finding. Repeat the accuracy check. If the accuracy check continues to fail remove from service and report, follow trust guidelines on reporting equipment faults.

When to Check Accuracy

- Monthly or after every 10 patients
- After annual maintenance checks

- After cleaning or disassembling spirometer for any reason
- After adjusting calibration
- If the flow head has been dropped

Error in calibration

Accuracy check variations > +/-3%/False readings suspected

In the event the accuracy check is outside the +/-3%, then refer to the manufacturer's manual on fault finding. Repeat the accuracy check. If the accuracy check continues to fail remove from service and report, follow trust guidelines on reporting equipment faults.

Maintenance .

To maintain quality assurance and accuracy of calibration, the spirometry must have a yearly service and certified calibration by the manufacture of the spirometer.

Reference

American Thorax Society (ATS) 1994 Guideline for the measurement of respiratory function

Respiratory Medicine 1994 (88), 165-194

Cleaning Procedure (Chest Clinic)

For lung function testing the main risks are:

- The cross infection of pathogenic organisms between patients
- The cross infection of pathogenic organisms to an immuno compromised patient, such as a lung transplant recipient.

The source of the infection must also be considered, the source could be airborne (coughing, sneezing) or body fluids (sputum, blood).

A new mouthpiece is to be used for each patient with a delay of 5 minutes in between patients to allow the particles to settle. In the event of visible contamination, the flowhead must be disinfected.

The cleaning protocol is based on the manufactures instructions, assuming 500 blows or 100 patients (modified from Vitalograph Alpha 6000 User manual)

PART	CLEAN/DISINFECT	FREQUENCY	CLEANING PRODUCT
Case exterior	Clean	After each patient	Sani-Cloth
Flow head tube	Clean	Weekly	Sani-Cloth
Screen	Clean	Daily	Wipe with cotton pad
Fleisch Element	Clean	Weekly	Immerse in Chlor clean tablets (to be made as protocol) for 15 minutes.
Flowhead body	Clean & Disinfect	Weekly	
Flowhead cone	Clean & Disinfect	Weekly	
Flowhead end cap	Clean & Disinfect	Weekly	
Flow conditioning mesh	Dispose & Replace	Weekly	

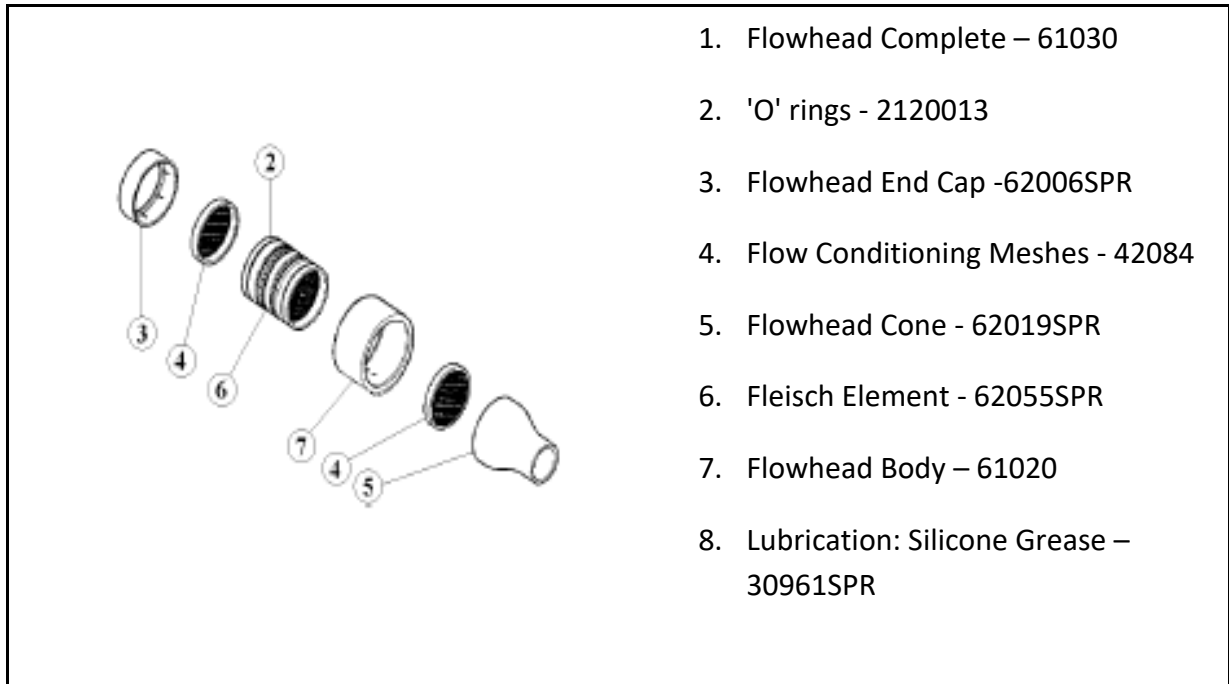

1. Flowhead Complete – 61030
2. 'O' rings - 2120013
3. Flowhead End Cap -62006SPR
4. Flow Conditioning Meshes - 42084
5. Flowhead Cone - 62019SPR
6. Fleisch Element - 62055SPR
7. Flowhead Body – 61020
8. Lubrication: Silicone Grease – 30961SPR

Figure 2: Flowhead Assembly (taken from Vitalograph Alpha 6000 User Manual)

Appendix 3: Respiratory referral Form

This respiratory referral form provided by King's Health Partners (KHP) Integrated Respiratory Team (IRT) is the preferred means by which any request for the following services should be made. After reviewing the referral criteria below please forward this form to any service required using the referral channel stated. **The service does not handle 2WW and TB referrals which should be referred directly.**

KHP Services for people with respiratory disease and symptoms

Service	Description of Service	Referral Channel
Specialist stop smoking service	This is a specialist stop smoking service for people with any long term condition. The service will provide intensive clinic and home based support in combination with appropriate pharmacotherapy. The service will contact the patient to advise where they can be seen.	EMAIL Southwark: 0800 169 6002 gst-tr.stopsmokingsouthwark@nhs.net Lambeth: 0800 856 3409 gst-tr.stopsmokinglambeth@nhs.net
Community Lung Function Service	This service will provide quality assured diagnostic standard spirometry for people with new respiratory symptoms and suspected respiratory disease such as COPD or asthma. They will also review patients where past spirometry results may not have achieved quality standards and when the results on reflection do not support the current diagnosis.	e-RS This is a directly bookable service and you can choose a number of community sites
Pulmonary Rehabilitation	Any patient with a long term lung condition who is functionally limited by breathlessness can benefit from pulmonary rehabilitation. This is especially important for patients with COPD and MRC breathlessness score 2 or more as long as any cardiac disease is stable.	e-RS You cannot directly book but the PR team will assess the referral and either contact the patient or return the referral with advice.
HOSAR – Home oxygen assessment and review	Any patient requiring home oxygen therapy needs to be seen / have the prescription issued by a specialist in oxygen therapy. For long term oxygen therapy (LTOT) this service will see any new patient with persistent finger pulse oximetry less than 92% despite optimal therapy and clinical stability. Current LTOT patients and ambulatory patients should have an annual review and they will be contacted directly by the service and do not require referral. Use this service also for people with Cluster Headache where a headache specialist has advised oxygen therapy.	e-RS This is a directly bookable service and you can choose the KCH or GSTT site.
Integrated respiratory team assessment at home (IRT)	If you have a patient who has COPD with complexity then the IRT can arrange a holistic review and home visit if appropriate. Please ensure you provide as much detail as possible and include the details of the lead clinician for this patient.	EMAIL and Phone King's: 0203 299 6531 kch-tr.IntegratedRespiratoryTeam@nhs.net St. Thomas': 07796 178719 gst-tr.integratedrespiratoryteamgstt@nhs.net Lines are available between 09:00 – 16:45 seven days per week.

Hospital Chest Clinic	Routine out-patient clinics for respiratory disease and symptoms. Please ensure you review the Lambeth and Southwark Breathlessness and Cough assessment algorithms as well SE London COPD and Asthma guidelines to avoid having your referral returned with requests for more information. Please ensure patients have had quality assured spirometry through the locality spirometry service before referral (as appropriate). The service does not handle 2WW and TB referrals.	e-RS This is a directly bookable service and you can choose KCH or GSTT Clinics depending on the condition being referred. Please select the most appropriate clinic.
------------------------------	--	---

Please check below to see where services are available and select any preference. For oxygen reviews or assessment we can liaise with neighbouring borough teams.	
Kings College Hospital – COPD, Asthma, HOSAR(oxygen), Pulmonary Rehab, Cough, Bronchiectasis, Sarcoid, Pleural, Sleep, General Chest	<input type="checkbox"/>
Guy’s Hospital – COPD, Asthma, HOSAR(oxygen), Interstitial lung disease, Sarcoid, Sleep	<input type="checkbox"/>
St Thomas’ Hospital – COPD, HOSAR (ambulatory oxygen), Pulmonary rehab, Pleural, General chest	<input type="checkbox"/>
Streatham Ice and Leisure centre (390 Streatham High Road, London SW16 6HX) - Pulmonary rehabilitation; community site	<input type="checkbox"/>
Dulwich Leisure Centre (Crystal Palace Road SE22 9HB) - Pulmonary rehabilitation; community site	<input type="checkbox"/>
Brixton Recreation Centre (Brixton Station Road SW9 8QQ) - Pulmonary rehabilitation; community site	<input type="checkbox"/>

Date of referral: Short date letter merged **Referrer Name:** Current User
Surgery: Organisation Full Address (single line)
Tel: Organisation Telephone Number E-mail: Organisation E-mail Address

Patient Details

NAME: Full Name **AGE: Age** **DOB: Date of Birth**
SEX: Gender
NHS Number: NHS Number **TEL: Patient Home Telephone** **MOBILE: Patient Mobile Telephone**
Patient EMAIL: Patient E-mail Address
Home Full Address (single line)
Ethnicity: Ethnic Origin **LANGUAGE: Main Language**

Add any further information that may help us co-ordinate this persons care e.g. transport needs:

What is the reason for the referral?

Describe the current problem briefly below and select recent consultations if this adds useful and relevant information. Please select only what is necessary to share with the recipient both to keep it short and to avoid information governance breaches. Please ensure you answer these two questions below in order to ensure timely onward referral.

What is the reason for this referral and what outcome do you and the patient expect?

Free Text Prompt

What tests or treatments have been tried so far?

Consultations

Problems

Medication

Allergies

Smoking

Respiratory values: Respiratory flow rates

Oxygen: Oxygen saturation at periphery...

Pro-brain natriuretic peptide: Serum pro-brain natriuretic peptide level...

MRC Breathlessness Scale: MRC Breathlessness Scale: grade 1...

Blood Pressure

Date and results of last chest X-ray

Infection risk?

Please attach any relevant spirometry or imaging reports.

If referring for spirometry, please give clinical authorisation for the administration of 400 mcg Salbutamol or 80mg Ipratropium Bromide below:

Name of Authorised prescriber:

following in the past 6 weeks

- Haemoptysis
- Heart attack or unstable angina
- Pulmonary embolism
- Pneumothorax
- Eye surgery
- Chest or abdominal surgery
- Chest, abdominal or cerebral aneurysm

Integrated Respiratory Team Telephone Advice line

Telephone support and advice for your patients with respiratory disease in Lambeth and Southwark. Providing assistance with managing exacerbations of COPD in the community. This service is provided by local Specialist Multidisciplinary Teams at King's College and St. Thomas' Hospital. Their contact details are;

King's: 0203 299 6531 / kch-tr.IntegratedRespiratoryTeam@nhs.net

St. Thomas': 07796 178719 / gst-tr.integratedrespiratoryteamgstt@nhs.net.

Lines are available between **09:00 – 16:45 seven days per week**